

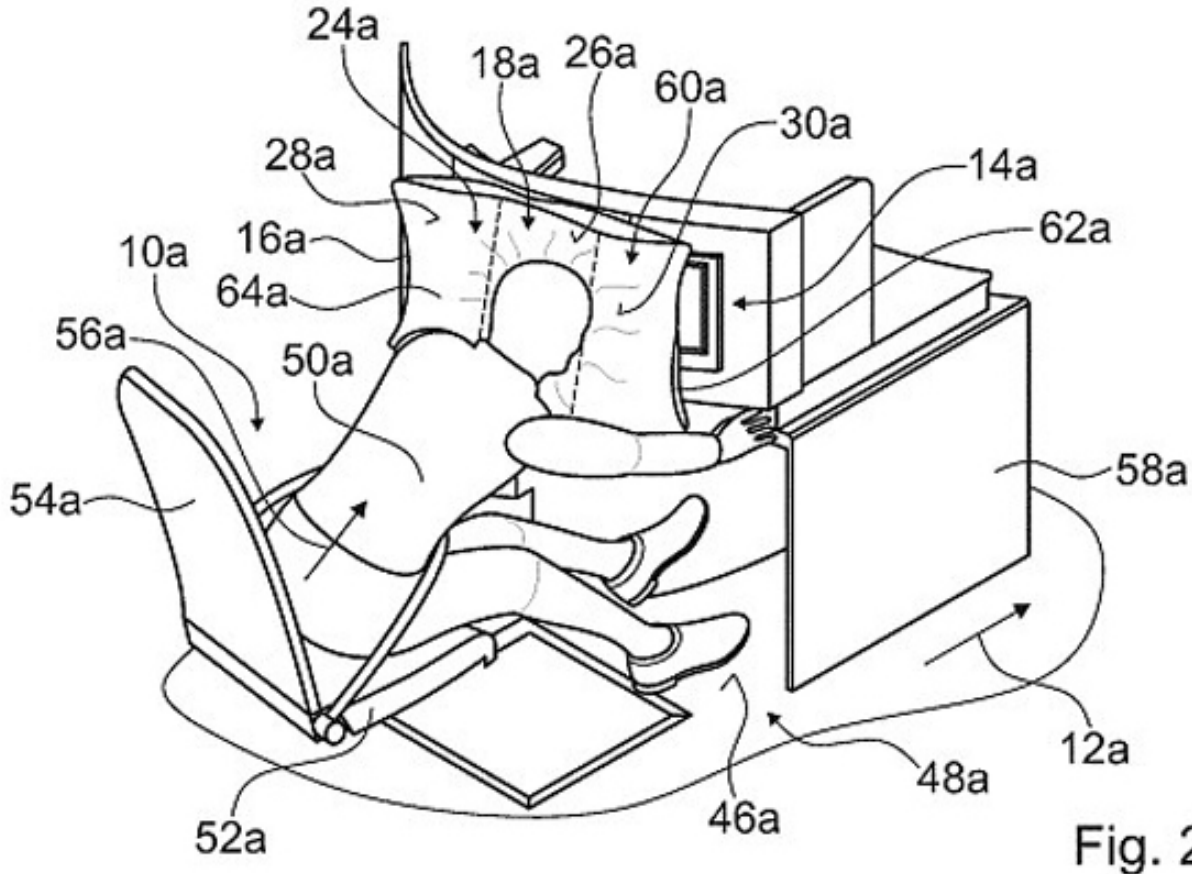

COULD PLANES OF THE FUTURE HAVE AIRBAGS FOR BUSINESS CLASS PASSENGERS?

News / Manufacturer



A company has designed a plane seat with an airbag to protect passengers.

The airbag, which would be fitted to business class seats, would deploy from a compartment next to the in-flight entertainment screen.

Germany firm Recaro designed the airbag which would be triggered in the event of a plane crash.

MailOnline reports that it would absorb the passenger's head and shoulders.

In January, a Ukrainian aviation engineer came up with an aircraft design that he believes would greatly increase your chance of surviving a plane crash.

It involves a detachable cabin that removes itself from the plane in the case of an emergency and would work regardless of whether the plane is taking off, flying at altitude or landing.

Inflatable rafts on the cabin would help it land smoothly on land or water.

Luggage would be stored underneath the passenger compartment, so you'd still have your luggage.

Unfortunately, the pilots wouldn't be in the section that would detach...

Bicycle-style seating

Image not found or type unknown

Bicycle-style seating

Airbus' 2014 patent for bicycle-style plane seats would mean a less comfortable flying experience and with more passengers packed in. The seats have no tray, headrest or much legroom, but just a small backrest. They are fastened to a vertical bar and retract to increase space when not in use. The patent was submitted with budget airlines in mind.

A 'vitalising zone'

Image not found or type unknown

A 'vitalising zone'

To allow people to fully relax on an aircraft, Airbus proposes a 'vitality zone' by 2050 "to bring the passenger closer to nature". According to the manufacturer, the "bionic structure and membrane will create the perfect combination of strength, light and space, offering panoramic views of the world outside through large areas where the lining can become transparent at the wave of a hand". The intelligent organically grown seats will sense your needs, offering massage, drinks, vitamins, or even a gentle sea breeze to wash over you.

Detachable cabins

Image not found or type unknown

Detachable cabins

Airbus came up with a new way to shave off turnaround time between flights in 2015 - by using detachable plane cabins. The French manufacturer's removable cabins could be swapped in and out of an aircraft to increase efficiency for boarding passengers. The concept would also allow planes to fly more frequently, with less time sitting and waiting on the ground.

Isolation helmets

Image not found or type unknown

Isolation helmets

For in-flight entertainment like no other, Airbus proposes an astronaut-style helmet which would allow passengers to fully immerse themselves in on-board entertainment. Designed by Frenchman Bernard Guering, the isolation helmet would block out all noise while packed with 3D and holographic video support. It would be operated by a remote control or motion capture gloves and would be air conditioned to make it comfortable to wear for a long period of time.

Standing-only areas

Image not found or type unknown

Standing-only areas

In 2010, Ryanair boss Michael O'Leary planned to introduce standing-only flights for travellers to fly for as little as £4 with the budget airline. The CEO wanted to remove the back ten rows of seats from the carrier's planes and replace them with 15 rows of vertical seats. Unfortunately for O'Leary, he was refused permission for test flights after the idea posed certain safety questions - particularly pertaining to how passengers would wear seatbelts. When asked how he envisioned the standing berths to be laid out, O'Leary replied: "Same as on the London Underground, handrails and straps."

'Flying doughnut' planes

Image not found or type unknown

Flying doughnut' planes

In a radical design from Airbus, the UFO-like 'flying doughnut' aircraft would see passengers board the plane via an escalator, entering a circular cabin with curved aisles and a hole in the middle. The futuristic plane would seat business class passengers within the inner ring and distribute cabin pressure more evenly, decreasing stress to the structure.

Cuddle chairs

Image not found or type unknown

Cuddle chairs

Boeing wants passengers to have better sleep in the air and in 2015 patented a bizarre "transport vehicle seat back with integrated upright sleep support system" known as the 'cuddle chair'. The chair features a cushion, headrest and strap system for forward-leaning sleep on flights.

Face-to-face seating

Image not found or type unknown

Face-to-face seating

Zodiac has come up with a new design for plane seats that would squeeze in as many people as possible. The catch? The 'Economy Class Cabin Hexagon' alternates the seats between facing forwards and backwards so you would be facing a fellow passenger - not the best feature if you're an anti-social traveller. The design promises increased shoulder room and an extra four inches of legroom. The bottoms of the seats can also be folded up to allow easy access to the middle and

windows seats so you won't have to clamber over fellow passengers to get to your seat.

Adjustable plane seats

Image not found or type unknown

Adjustable plane seats

Adjustable plane seats could be the answer to offering more legroom to passengers, according to Aerospace. A patent submitted in 2015 detailed the plane seats that would roll back and forth to give tall passengers more legroom and short passengers less. The system works on aircrafts' already-existing tracks, with each seat fitted with wheels that run on the track.

Windowless planes

Image not found or type unknown

Windowless planes

The boffins at Aerospace are working to bring windowless planes to the skies by replacing conventional windows with responsive screens that would show passengers whatever they want - the clouds outside or interactive websites. The high-tech screens would mean planes are lighter, saving airlines money in fuel.

Windowless cockpits

Image not found or type unknown

Windowless cockpits

This is a strange one... a cockpit without windows? In a patent submitted by Airbus, pilots would fly aircrafts using 3D view screens instead of traditional windows. Laser-formed holograms and feeds from on-board cameras would also feature. According to the manufacturer, pilots would benefit from a wider field of vision and the windowless cockpits would allow aircraft designers to put pilots anywhere on the plane.

Sleeping boxes

Image not found or type unknown

Sleeping boxes

Sleeping stretched out in a plane seat won't always be reserved for business and first class travellers if Airbus' 2015 patent for economy sleeping pods is anything to go by. Long-haul travellers may eventually get their own 'sleeping boxes' which would be stacked at the back of the aircraft. The pods would have personal televisions, reclining pillows, a reading light and video cameras for cabin crew to monitor passengers throughout the flight.

27 MARCH 2016

SOURCE: AOL

ARTICLE LINK:

<https://50skyshades.com/index.php/news/manufacturer/could-planes-of-the-future-have-airbags-for-business-class-passengers>