



NEW HAV PARTNER PROGRAMME TO SUPERCHARGE FUTURE AIRLANDER 50 DESIGN

News / Manufacturer



Hybrid Air Vehicles launches a new partner programme which will enable key partners and customers to influence, optimise and propel forward the design specification of Airlander 50. As Airlander 10 gears up to go into full-scale production, Airlander 50 is the next development step on Hybrid Air Vehicles' journey, using Airlander technology to deliver a future of sustainable air freight transport for heavy lift, remote access and outsize cargos.

The Airlander 50 Development Partner Programme aims to understand the requirements of its future customers and use the regular insights and feedback from partners to shape and inform its conceptual design. Lead partners include [AECOM](#), the world's trusted infrastructure consulting firm and sustainable global fruits supplier [Blue Skies Holdings](#), which operates in Africa to produce fruit based products for European retailers.

Unlike HAV's first aircraft, Airlander 10, the Airlander 50 is optimised for logistics and freight transport, owing to its ability to carry a payload of 50-60 tonnes, and cargoes as large as 6 ISO shipping containers. Like Airlander 10, Airlander 50 will be able to move cargo or people point-to-point with minimal infrastructure. It will enable its users to bypass congested infrastructure such as ports, connect services to underserved locations, and avoid intermodal steps that currently interrupt journeys by sea, road and rail.

Airlander offers more available payload volume per unit weight compared to other aircraft. This enables it to transport outsize items such as wind turbines or supplies to remote mines - which can currently be difficult and expensive to move to their final destination.

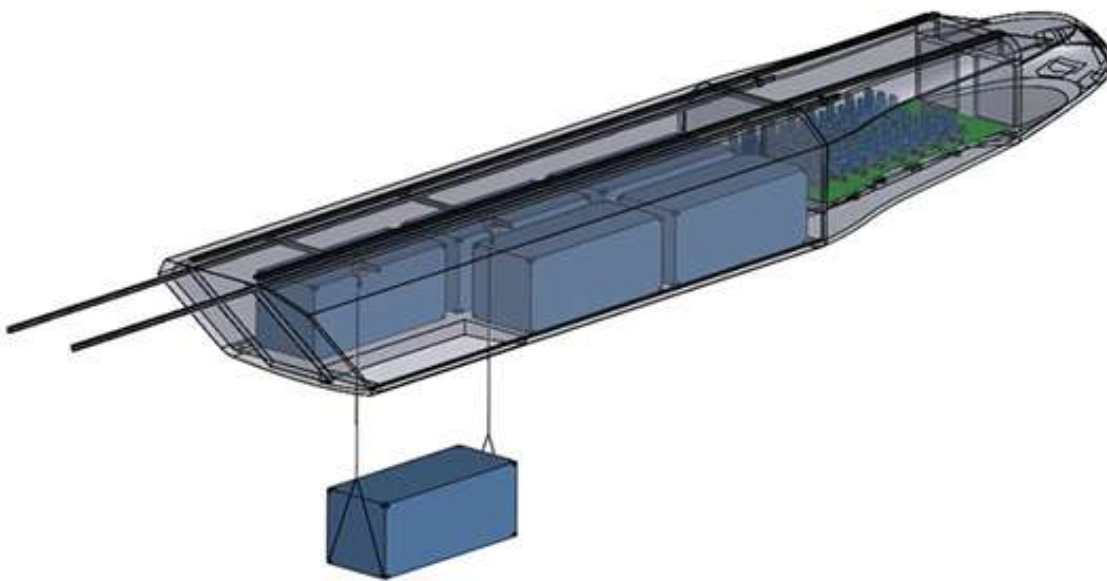

Airlander 50 offers the potential to rapidly scale up a new set of affordable logistics connections. As with all Airlander aircraft, this will be achieved with minimal impact on the environment, delivering sustainable, large-scale air freight. The Partner Programme will explore the range of these potential uses and their influence on vehicle design.

George Land, Commercial Business Development Director of Hybrid Air Vehicles commented: "Airlander 50 will be the next member of the Airlander family of aircraft that follows Airlander 10. Today we are very pleased to be launching the Development Partner Programme for this aircraft, enabling us to refine its specification using real world use cases and feedback from a diverse set of potential customer, operator and infrastructure partners."

The Airlander 50 development programme partners consist of prospective future customers, including leading partner, AECOM, who will play an instrumental role in testing viability and determining supporting infrastructure needs.

AECOM Chief Executive for Europe and India Colin Wood said: "The technology and design

intelligence to enable low carbon aviation is moving at a rapid pace and it is through collaboration that we can innovate to bring impactful solutions to market quickly. We have committed to reducing carbon emissions as part of our Sustainable Legacies strategy and this Development Partner Programme brings the opportunity to shape and support delivery of the Airlander 50, which is a hugely important project in the drive to reduce carbon emissions from the freight transportation sector.”

The programme will comprise of structured dialogue and regular meetings which focus on fine tuning the design and logistics of Airlander 50 with input from leading experts. The participants will also be able to put forward their specific use cases for Airlander 50 to enable investigation into their operational practicality and economic feasibility. Other partners include Infinergy and Highlands and Islands Airports Limited.

A spokesperson from Blue Skies Holdings said: “The Airlander project provides an exciting opportunity for Blue Skies. Moving products and raw materials between countries, particularly in West Africa, can be difficult due to challenging road conditions, border delays and a measure of bureaucracy. Blue Skies is very interested in Airlander as it will enable the business to move raw materials from farms to factories with greater efficiency and with a vastly reduced carbon footprint.”

The news follows HAV’s recent landmark announcement which saw Airlander 10 secure its first airline carrier customer, Air Nostrum Group.

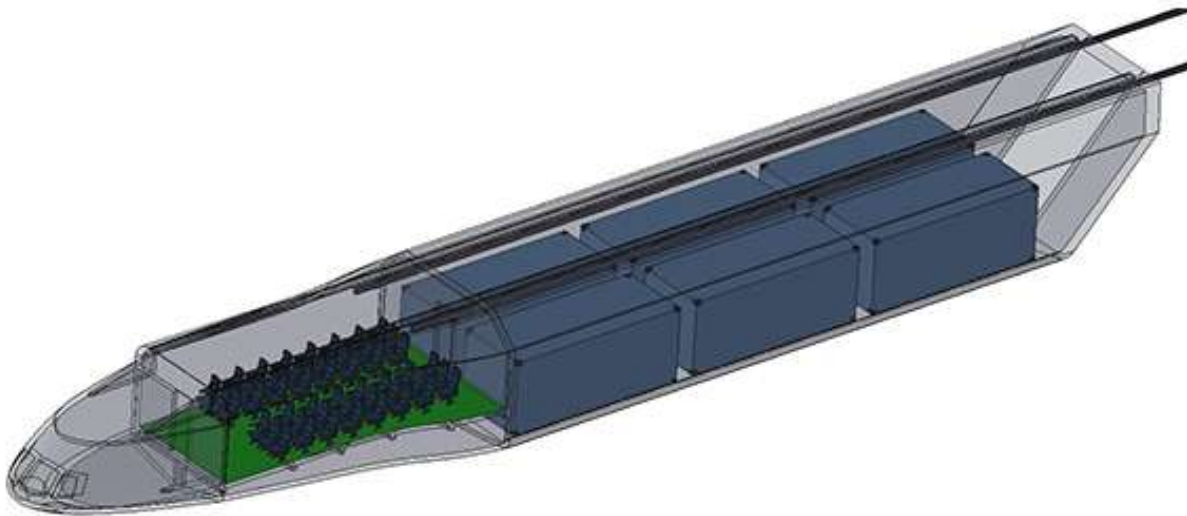

19 JULY 2022

ARTICLE LINK:

<https://50skyshades.com/index.php/news/manufacturer/new-hav-partner-programme-to-supercharge-future-airlander-50-design>